

1000 – 8000 SERIES CRYOGENIC BAR STOCK BODY VALVES 1/2” – 2” Sizes

TABLE OF CONTENTS

INSTALLATION.....	2
GENERAL NOTES.....	2
WELDING VALVE IN PIPELINE.....	2
PNEUMATIC AND ELECTRICAL CONNECTIONS.....	2
OPERATION.....	2
HANDWHEEL (MANUAL).....	2
DIRECT ACTING (NORMALLY OPEN, AIR-TO-CLOSE) PNEUMATIC ACTUATOR.....	2
REVERSE ACTING (NORMALLY CLOSED, AIR-TO-OPEN) PNEUMATIC ACTUATOR.....	3
START-UP.....	3
MAINTENANCE.....	3
GENERAL NOTES - IMPORTANT.....	3
MANUAL: STANDARD, OS&Y, AND OS&Y BELLOW SEAL.....	3
<i>Disassembly</i>	3
<i>Reassembly</i>	4
AUTOMATIC: STANDARD AND BELLOW SEAL.....	6
<i>Disassembly</i>	7
<i>Reassembly</i>	7
LIFT CHECK.....	9
<i>Disassembly</i>	9
<i>Reassembly</i>	9

TABLE OF FIGURES

FIGURE 1 - STANDARD MANUAL VALVE.....	4
FIGURE 2 - OS&Y MANUAL VALVE.....	5
FIGURE 3 - OS&Y BELLOW SEAL MANUAL VALVE.....	5
FIGURE 4 - OS&Y MANUAL WITH LIVE LOADED PACKING.....	6
FIGURE 5 - STANDARD AUTOMATIC VALVE.....	8
FIGURE 6 - BELLOW SEAL AUTOMATIC VALVE.....	8
FIGURE 7 - LIFT CHECK VALVE.....	9
FIGURE 8 - SEAT RETAINER NUT TORQUE.....	10
FIGURE 9 - STANDARD MANUAL VALVE PACKING NUT TORQUE.....	10
FIGURE 10 - OS&Y MANUAL VALVE PACKING BOLT AND NUT TORQUE.....	11
FIGURE 11 - AUTOMATIC VALVE PACKING FOLLOWER TORQUE.....	11
FIGURE 12 - VALVE MOUNTING ORIENTATIONS.....	12
FIGURE 13 - BODY/BONNET BOLT AND NUT TORQUE.....	13

CAUTION!

The piping system must be adequately designed and supported to prevent extraordinary loads to the pressure equipment.

INSTALLATION

GENERAL NOTES

Prior to installation, the valve assembly should be unpacked and checked against the packing list and/or the approved customer drawing.

Valves are recommended for installation in the flow-to-open orientation (under seat port to be inlet connection). Globe valves can be mounted in a horizontal pipe run with the actuator or handwheel located above the pipeline and no more than 15° to either side of the valve's vertical centerline. Y-pattern valves can be mounted in a horizontal pipe run with the actuator or handwheel located above the pipeline and no more than 45° to either side of the valve's vertical centerline, and they can be mounted in a vertical pipe run with the actuator or handwheel located above the horizontal. Right angle valves can be mounted in a vertical pipe run with the actuator or handwheel located above the pipeline and no more than 45° to either side of the valve's vertical centerline. See Figure 12 (located toward the back of this manual) for an illustration of valve mounting orientations.

The valve is not to be installed or used in a pipeline that exceeds the maximum allowable working pressure as listed on the valve tag.

Support the actuator as necessary to avoid inducing extraordinary loads to the bonnet extension and pipeline (especially when installing Y-pattern valves).

For oxygen clean and high purity valves, care must be taken to ensure the level of cleanliness is not compromised during the installation process.

WELDING VALVE IN PIPELINE

Prior to welding, insure pipeline is clean and free from dirt, weld slag, machining burrs, and pipe scale. The valve ports are identified with a label as "OS", for over seat, and "US", for under seat.

The valve does not require disassembly to be welded in the pipeline due to the end connection extensions, however it is recommended the valve be in the open

position prior to welding. This will minimize any heat conducting to the Kel-F® seat. Support the valve properly until welded into the pipeline.

Weld valve into the pipeline in accordance with any and all applicable local and national codes and standards.

After installation, if system flushing is necessary, first remove the inner cylinder/plug assembly (see MAINTENANCE Section) to protect the Kel-F® seat.

PNEUMATIC AND ELECTRICAL CONNECTIONS

If applicable, see the appropriate instruction manual shipped with the valve for the installed actuator, positioner, filter/regulator, solenoid, and/or limit switches.

When making pneumatic connections, it is recommended that PTFE tape or paste is used on threaded joints, unless otherwise specified by the components instruction manual. The pneumatic supply should be clean, dry air or nitrogen.

When making electrical connections, wiring of components should be in accordance with any and all applicable local and national codes and standards.

OPERATION

HANDWHEEL (MANUAL)

The valve is actuated by manually turning the handwheel. The valve opens when the top face of the handwheel is turned counter-clockwise. The valve closes when the top face of the handwheel is turned clockwise. It is not recommended to use spanner wrenches or cheater bars when seating the valve.

DIRECT ACTING (NORMALLY OPEN, AIR-TO-CLOSE) PNEUMATIC ACTUATOR

In this configuration, the actuator contains springs that provide an upward force to open the valve upon decreasing pneumatic supply pressure. Therefore, the valve closes with increasing pneumatic supply pressure. See the actuator instruction manual and data plate for additional information.

REVERSE ACTING (NORMALLY CLOSED, AIR-TO-OPEN) PNEUMATIC ACTUATOR

In this configuration, the actuator contains springs that provide a downward force to close the valve upon decreasing pneumatic supply pressure. Therefore, the valve opens with increasing pneumatic supply pressure. The required pre-load to achieve standard bubble tight shut-off is factory set. See the actuator instruction manual and data plate for further information.

START-UP

After initial cool down, check and re-tighten packing and body/bonnet fasteners as needed (see GENERAL NOTES in the MAINTENANCE Section).

MAINTENANCE

WARNING!

Injury or death can occur due to failure to completely isolate equipment from all sources of pressure before beginning disassembly. Do not proceed until valve has been completely isolated from the process and vented to atmospheric pressure.

GENERAL NOTES - IMPORTANT

Standard maintenance kits for valves include a soft goods kit to replace all elastomeric seals and a change out, or top works, kit to replace the entire valve except for the body. Change out kits are provided pre-assembled, ready to drop into the valve body, and can be used to convert manual valves to automatic and vice versa.

Apply Krytox® or any other suitable lubricant to all threads (manual stem threads, body/bonnet fasteners, and packing fasteners) and o-rings prior to reassembly. NOTE: Lubricant must be compatible with process fluid.

Apply NIKAL® (nickel anti-seize compound) or any other suitable lubricant to yoke lock nut (on automatic actuator valves) for ease of disassembly.

Kel-F® seat fasteners and body/bonnet fasteners are to be tightened per Fig.'s 8 & 13, respectively.

Packing fasteners/nuts for manual bellow seal valves are to be tightened per Fig. 10, and packing fasteners for automatic bellow seal valves are to be tightened per Fig. 11.

Packing fasteners/nuts for all non-bellow seal valves are to be tightened enough to prevent leakage under operating conditions only. Over tightening reduces the packing life and causes excessive friction forces on the valve stem, leading to higher actuation force and premature degradation of valve performance. Initial recommended torques for non-bellow seal valves are listed in Fig.'s 9, 10, & 11.

MANUAL: STANDARD, OS&Y, AND OS&Y BELLOW SEAL

Please refer to Fig.'s 1, 2, 3, and 4 for a basic illustration of these valves. The number in parenthesis refers to the item number in the specified figures.

Disassembly

Change Out/Top Works Kit

After ensuring the valve is isolated from all sources of pressure and fully depressurized, remove the body/bonnet fasteners (2), and pull the top works out of the valve body assembly (1).

If present, the inner cylinder (3) can be detached by sliding it off the valve stem (4). In Manual OS&Y bellows seal ½" to 1" valves, slide the Teflon sleeve (18 in Fig. 3) off the bellows after removing the inner cylinder. NOTE: The 3000 and 6000 series valves do not contain an inner cylinder.

Soft Goods Kit (Packing, Seat Disc, and Gaskets)

To initially access the internal components, refer to the instructions above. To remove the packing (5) for the standard manual valve (see Fig. 1), remove the hand wheel nut (6) and pull off the hand wheel (7), then remove the packing nut (8) and rotate the stem to extract from the bottom of the bonnet (9). Remove the packing follower (10) and the packing. Take care not to scratch the stem and packing sealing surfaces.

To remove the packing (5) for the OS&Y manual valves (see Fig.'s 2 and 3), remove the packing nuts (8) and packing flange (11), and then turn the hand wheel (7) clockwise while holding the yoke (9) still. Once the stem threads disengage, pull the stem out from the bottom of the yoke. Remove the packing follower (10) and the packing. Take care not to scratch the stem and packing sealing surfaces.

To remove the packing for the OS&Y manual valves with live loaded packing (see Fig. 4), remove the packing nuts (4), packing bolts (1), Belleville washers (2), and flat washers (3). Turn the hand wheel clockwise while holding the yoke still. Once the stem threads disengage, pull the stem out from the bottom of the yoke. Remove the packing flange,

packing follower (10), packing and stem guide. Take care not to scratch the stem and packing sealing surfaces.

To remove the seat disc (12), remove the seat disc nut (13) and slide off the seat disc retainer (14). The seat disc can now be removed.

NOTE: The seat disc retainer may be different than shown in the figures. The retainer may be profiled for linear or equal percentage flow. To remove the bonnet gasket (15), carefully extract the bonnet gasket from its groove; prevent scratching of the sealing surfaces.

Reassembly

Soft Goods Kit (Packing, Seat Disc and Gaskets)

To install a change out or top works kit only, refer to the instructions below.

Install the new packing into the packing gland. For Teflon® chevron packing, install the packing set so that the point is up and the v-pocket is facing the pressure. Install the stem guide or wiper ring (16) first followed by the packing rings.

Install the new o-rings (17) on the packing follower. Please refer to the GENERAL NOTES under MAINTENANCE section for important information regarding the proper lubrication of the o-rings prior to installation. Replace the packing nut, or packing flange and associated fasteners, and tighten according to instructions in GENERAL NOTES under MAINTENANCE section. For valves with live loaded packing (Fig. 4), place the Belleville washers (2) and flat washers (3) onto the packing bolts (1). Place the packing bolt through the packing flange and bonnet. Tighten the packing nut (4) onto the shoulder bolt until it stops on the shoulder.

Thread the valve stem up through the bonnet. For the standard manual valve, thread the stem up into the bottom of the bonnet. For the OS&Y manual valves, place the yoke over the stem and lower until the stem threads meet the yoke threaded gland. While holding the yoke still, rotate the hand wheel counter-clockwise. NOTE: For OS&Y type valves, place the body/bonnet bolts through the bonnet flange prior to re-inserting the stem. Additionally, for bellow seal valves, install the bonnet gasket (15) in the stem assembly flange prior to re-inserting the stem.

Install the new seat disc onto the plug. Ensure the beveled edge of the seat disc faces away from the plug serrations and toward the valve body seat. Replace the seat disc retainer and the seat disc nut. Tighten and stake the seat disc retainer nut per Figure 7, located toward the back of this manual.

Change Out/Top Works Kit

Replace the existing bonnet gasket (15) in the valve body assembly. Use care when extracting the existing bonnet gasket to preserve the surface finish of the groove. For Manual OS&Y Bellows Seal ½" to 1" valves, replace the Teflon sleeve (18 on Fig. 3) onto the bellows.

Attach the inner cylinder to the stem assembly. Turn the handwheel so that the plug is in the open position. Slide the top works in the valve body assembly and fasten the body/bonnet bolts according to the torque and sequence procedure per Figure 12, located toward the back of this manual. Fully open and close the valve, checking for smooth operation. With the valve in mid-stroke position, pressurize the valve and check for leaks at the body/bonnet connection and packing gland. Close the valve, and depressurize the downstream side to check for seat tightness.

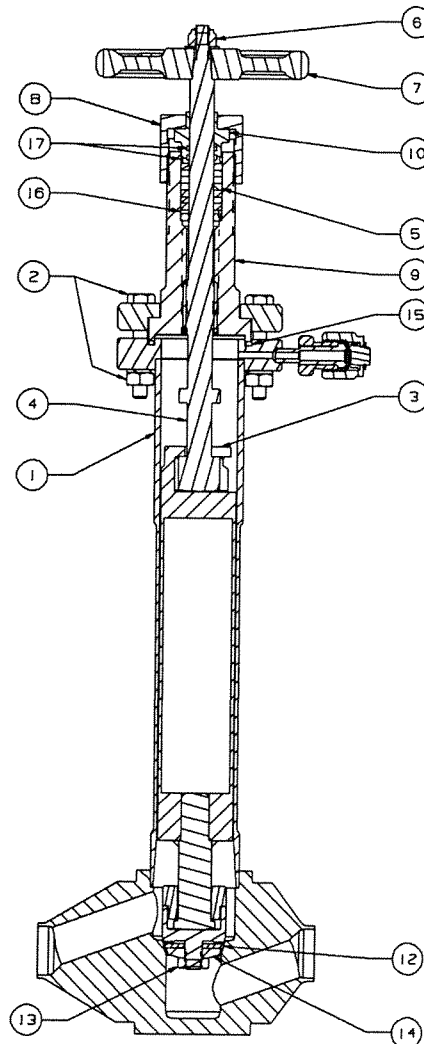

Figure 1 - Standard Manual Valve

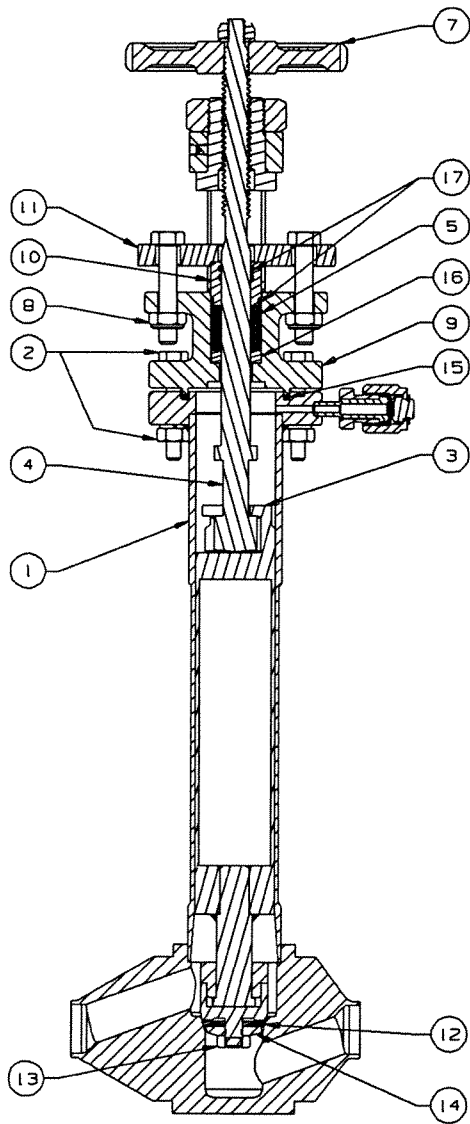

Figure 2 - OS&Y Manual Valve

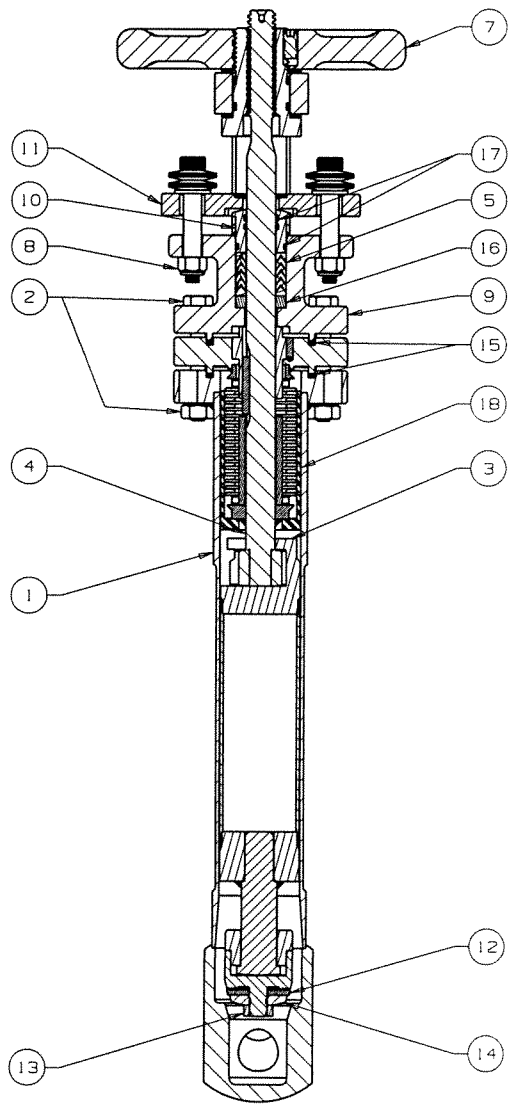

Figure 3 - OS&Y Bellow Seal Manual Valve

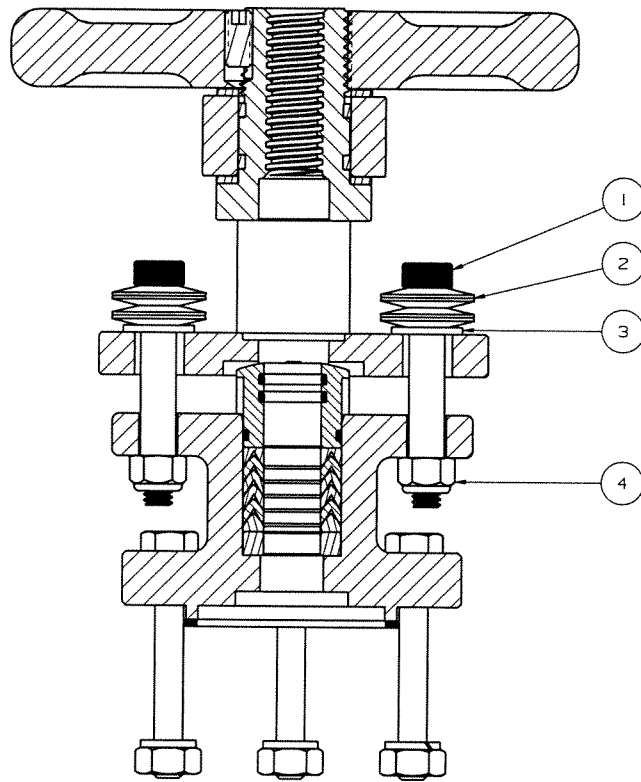

Figure 4 – OS&Y Manual with Live Loaded Packing

AUTOMATIC: STANDARD AND BELLOW SEAL

Please refer to Fig.'s 5 and 6 for a basic illustration of these valves. The number in parenthesis refers to the item number in the specified figures.

Disassembly

Change Out/Top Works Kit

After ensuring the valve is isolated from all sources of pressure and fully depressurized, remove the body/bonnet fasteners (2), and pull the top works out of the valve body assembly (1).

If present, the inner cylinder (3) can be detached by sliding it off the valve stem (4).

NOTE: The 3000 and 6000 series valves do not contain an inner cylinder.

Soft Goods Kit (Packing, Seat Disc, and Gaskets)

To initially access the internal components, refer to the instructions above. Remove the actuator according to the instructions supplied with the actuator.

To remove the packing (5), loosen the packing retainer lock nut (8) and remove the packing follower (10). Pull the stem to extract from the bonnet (9). Remove the packing. Take care not to scratch the stem and packing sealing surfaces.

To remove the seat disc (12), remove the seat disc nut (13) and slide off the seat disc retainer (14). The seat disc can now be removed.

NOTE: The seat disc retainer may be different than shown in the figures. The retainer may be profiled for linear or equal percentage flow.

To remove the bonnet gasket (15), carefully extract the bonnet gasket from its groove; prevent scratching of the sealing surfaces.

Reassembly

Soft Goods Kit (Packing, Seat Disc, and Gaskets)

To install a change out or top works kit only, refer to the instructions below.

Install the new packing into the packing gland. For Teflon® chevron packing, install the packing set so that the point is up and the v-pocket is facing the pressure. Install the stem guide or wiper ring (16) first followed by the packing rings.

Install the new o-rings (17) on the packing follower. Please refer to the GENERAL NOTES under MAINTENENCE section for important information regarding the proper lubrication of the o-rings prior to installation. Replace the packing follower and the

packing retainer lock nut, and tighten according to instructions in GENERAL NOTES under MAINTENENCE section.

Carefully insert the valve stem up through the bonnet. For bellow seal valves, install the bonnet gasket (15) in the stem assembly flange prior to re-inserting the stem.

Install the new seat disc onto the plug. Ensure the beveled edge of the seat disc faces away from the plug serrations and toward the valve body seat. Replace the seat disc retainer and the seat disc nut. Tighten and stake the seat disc retainer nut per Figure 8, located toward the back of this manual.

Change Out/Top Works Kit

Replace the existing bonnet gasket (15) in the valve body assembly. Use care when extracting the existing bonnet gasket to preserve the surface finish of the groove.

Attach the inner cylinder to the stem assembly. With the plug in the open position, slide the top works in the valve body assembly and fasten the body/bonnet bolts according to the torque and sequence procedure per Figure 13, located toward the back of this manual.

Fully open and close the valve, checking for smooth operation. With the valve in mid-stroke position, pressurize the valve and check for leaks at the body/bonnet connection and packing gland. Close the valve, and depressurize the downstream side to check for seat tightness.

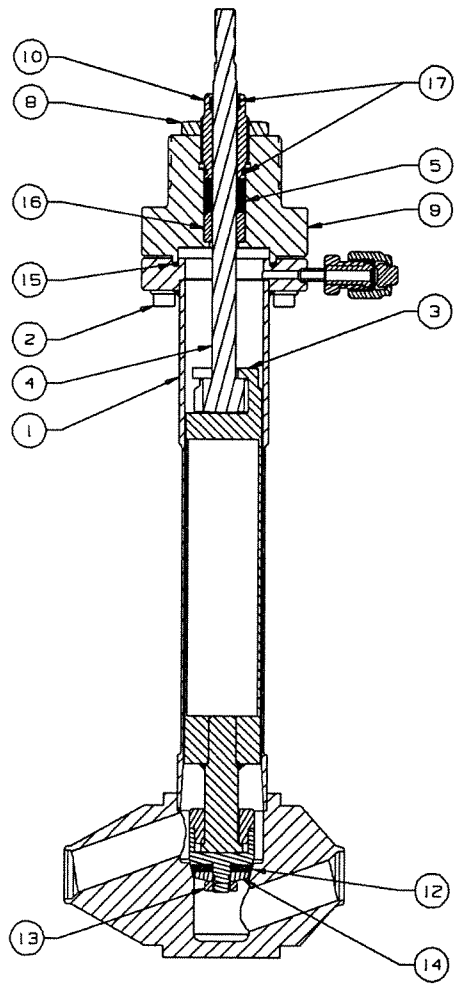

Figure 5 - Standard Automatic Valve

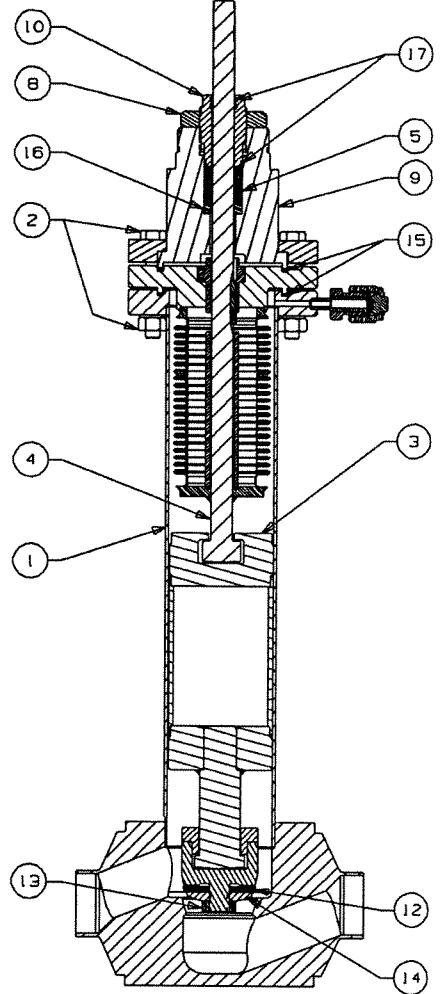

Figure 6 - Bellows Seal Automatic Valve

LIFT CHECK

Please refer to Fig. 7 for a basic illustration of these valves. The number in parenthesis refers to the item number in the specified figure.

Disassembly

Change Out/Top Works Kit

After ensuring the valve is isolated from all sources of pressure and fully depressurized, remove the body/bonnet fasteners (2), and pull the top works out of the valve body assembly (1).

If present, the inner cylinder (3) can be detached by sliding it off the valve stem (4).

NOTE: The 3000 and 6000 series valves do not contain an inner cylinder.

Soft Goods Kit (Seat Disc and Gasket)

To initially access the internal components, refer to the instructions above.

To remove the seat disc (12), remove the seat disc nut (13) and slide off the seat disc retainer (14). The seat disc can now be removed.

NOTE: The seat disc retainer may be different than shown in the figures. The retainer may be profiled for linear or equal percentage flow.

To remove the bonnet gasket (15), carefully extract the bonnet gasket from its groove; prevent scratching of the sealing surfaces.

Reassembly

Soft Goods Kit (Seat Disc and Gasket)

To install a change out or top works kit only, refer to the instructions below.

Install the new seat disc onto the plug. Ensure the beveled edge of the seat disc faces away from the plug serrations and toward the valve body seat. Replace the seat disc retainer and the seat disc nut. Tighten and stake the seat disc retainer nut per Figure 8, located toward the back of this manual.

Change Out/Top Works Kit

Replace the existing bonnet gasket (15) in the valve body assembly. Use care when extracting the existing bonnet gasket to preserve the surface finish of the groove.

Attach the inner cylinder to the stem assembly. Slide the top works in the valve body assembly and fasten the body/bonnet bolts according to the torque and sequence procedure per Figure 13, located toward the back of this manual.

Pressurize the valve normally (flow under the seat) and check for leaks at the body/bonnet connection and packing gland. At your discretion, backflow the valve, and depressurize the upstream side to check for seat tightness.

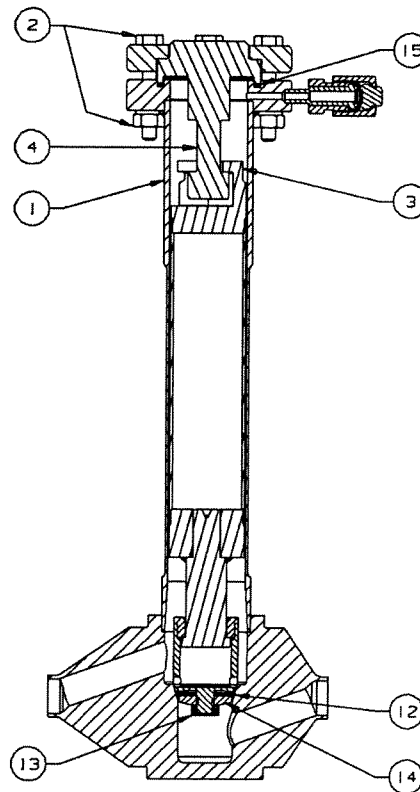

Figure 7 - Lift Check Valve

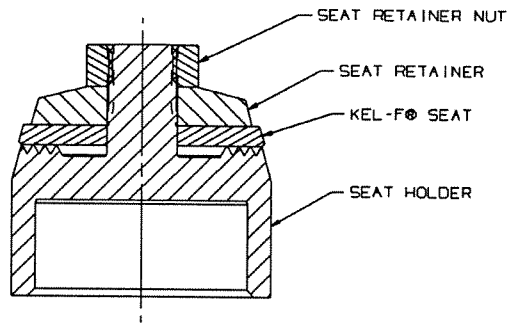
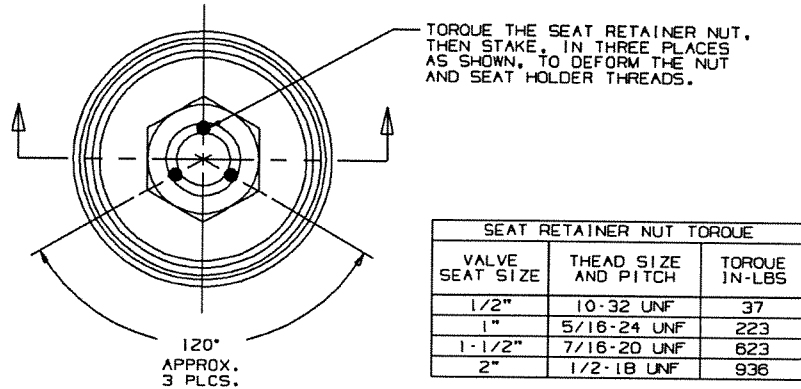
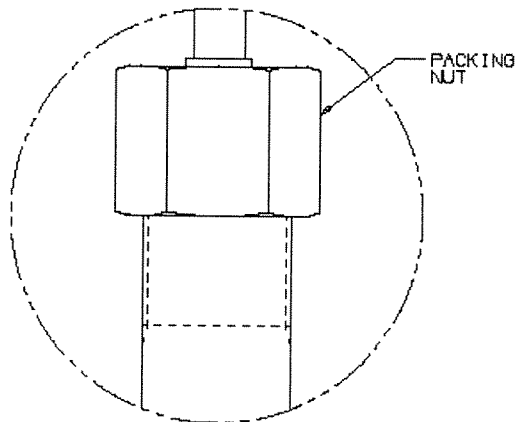

Figure 8 - Seat Retainer Nut Torque



STANDARD MANUAL VALVE PACKING NUT TORQUE		
VALVE SIZE	PACKING MATERIAL	TORQUE IN-LBS
1/2" - 1"	PTFE	60
1/2" - 1"	GRAPHITE	140
1-1/2" - 2"	PTFE	72
1-1/2" - 2"	GRAPHITE	140

NOTE: THE VALUES LISTED ARE INITIAL RECOMMENDED TORQUE VALUES. SEE THE GENERAL NOTES UNDER THE MAINTENANCE SECTION FOR MORE INFORMATION.

TORQUE VALUES SHOULD BE CHECKED AFTER THE FIRST GOLD CYCLE AND RE-CHECKED ON AN ANNUAL BASIS OR AS NEEDED.

Figure 9 - Standard Manual Valve Packing Nut Torque

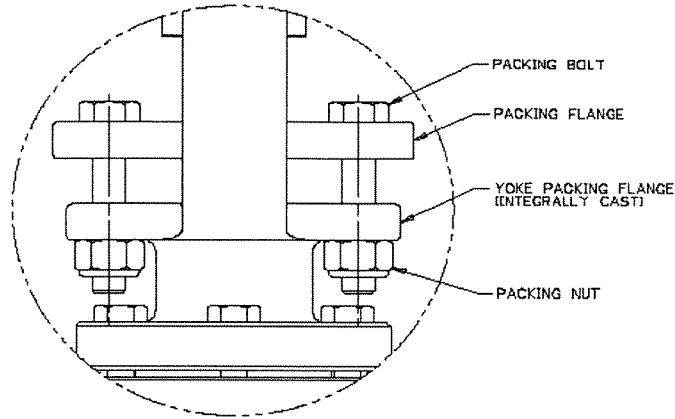

OS&Y MANUAL VALVE PACKING BOLT AND NUT TORQUE				
VALVE SIZE	PACKING MATERIAL	50% TORQUE IN-LBS	75% TORQUE IN-LBS	100% TORQUE IN-LBS
1/2" - 2"	PTFE	20	30	40
1/2" - 2"	GRAPHITE	35	52	70

NOTE: FOR NON-BELLOW SEAL VALVES, THE VALUES LISTED ARE INITIAL RECOMMENDED TORQUE VALUES. SEE THE GENERAL NOTES UNDER THE MAINTENANCE SECTION FOR MORE INFORMATION.

- TORQUE SEQUENCE:
 ALTERNATE BETWEEN BOLTS TO KEEP THE PACKING FLANGE PARALLEL TO THE YOKE PACKING FLANGE.
1. SNUG BOLT AND NUT FINGER TIGHT.
 2. TIGHTEN TO 50% REQUIRED TORQUE.
 3. TIGHTEN TO 75% REQUIRED TORQUE.
 4. TIGHTEN TO 100% REQUIRED TORQUE.

TORQUE VALUES SHOULD BE CHECKED AFTER THE FIRST COLD CYCLE AND RE-CHECKED ON AN ANNUAL BASIS OR AS NEEDED.

Figure 10 - OS&Y Manual Valve Packing Bolt and Nut Torque

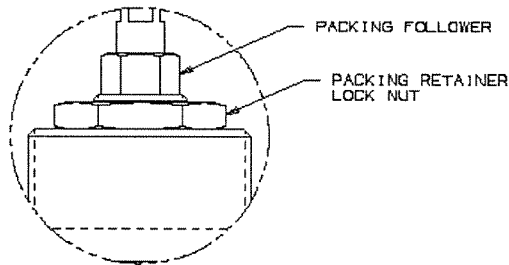

AUTOMATIC VALVE PACKING FOLLOWER TORQUE		
VALVE SIZE	PACKING MATERIAL	TORQUE IN-LBS
1/2" - 1"	PTFE	60
1/2" - 1"	GRAPHITE	140
1-1/2" - 2"	PTFE	72
1-1/2" - 2"	GRAPHITE	144

NOTE: FOR NON-BELLOW SEAL VALVES, THE VALUES LISTED ARE INITIAL RECOMMENDED TORQUE VALUES. SEE THE GENERAL NOTES UNDER THE MAINTENANCE SECTION FOR MORE INFORMATION.

- TORQUE SEQUENCE:
1. LOOSEN THE PACKING RETAINER LOCK NUT.
 2. TIGHTEN THE PACKING FOLLOWER TO THE REQUIRED TORQUE.
 3. TORQUE THE PACKING RETAINER LOCK NUT TO 120 IN-LBS.

TORQUE VALUES SHOULD BE CHECKED AFTER THE FIRST COLD CYCLE AND RE-CHECKED ON AN ANNUAL BASIS OR AS NEEDED.

Figure 11 - Automatic Valve Packing Follower Torque

GLOBE :

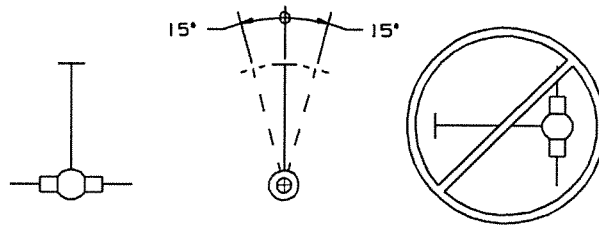

Y-PATTERN :

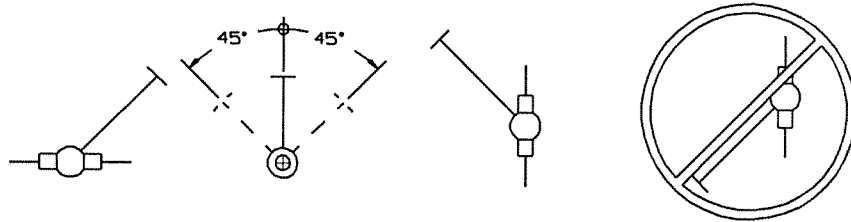

RIGHT ANGLE :

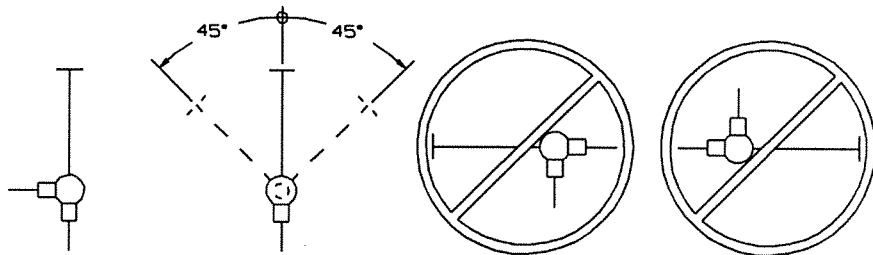
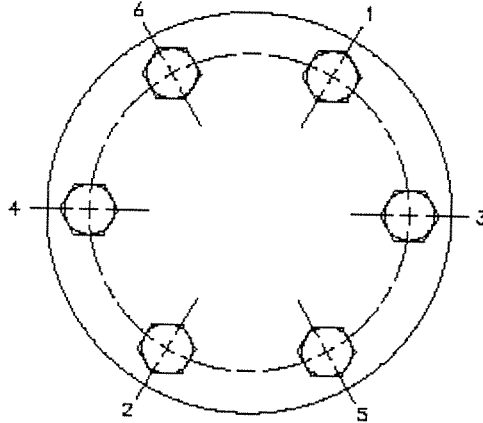

Figure 12 - Valve Mounting Orientations



BODY/BONNET BOLT AND NUT TORQUE (TEFLON)				
VALVE SIZE	THREAD SIZE AND PITCH	50% TORQUE IN-LBS	75% TORQUE IN-LBS	100% TORQUE IN-LBS
1/2"	10-32 UNF	19	28	37
1/2" THRU 1"	1/4-20 UNC	50	75	100
1-1/2" and 2"	5/16-18 UNC	103	155	206
3"	7/16-14 UNC	286	429	572
AUTOMATIC VALVES USING SOCKET HEAD CAP SCREWS				
1/2" THRU 1"	1/4-20 UNC	51	77	102
1-1/2" and 2"	5/16-18 UNC	100	150	200
3"	7/16-14 UNC	272	436	544

TORQUE SEQUENCE:

1 TO 2, 2 TO 3, 3 TO 4, 4 TO 5, 5 TO 6

1. SNUG BOLTS AND NUTS FINGER TIGHT.
2. TIGHTEN TO 50% REQUIRED TORQUE.
3. TIGHTEN TO 75% REQUIRED TORQUE.
4. TIGHTEN TO 100% REQUIRED TORQUE.

TORQUE VALUES SHOULD BE CHECKED AFTER THE FIRST COLD CYCLE AND RE-CHECKED ON AN ANNUAL BASIS OR AS NEEDED.

Figure 13 - Body/Bonnet Bolt and Nut Torque

It is solely the responsibility of the system designer and the user to select products and materials suitable for their specific application requirements and to ensure proper installation, operation and maintenance of these products. Assistance shall be afforded with the selection of the materials based on the technical information supplied to CPC-Cryolab™; however, the system designer and user retain final responsibility. The designer should consider applicable Codes, material compatibility, product ratings and application details in the selection and application. Improper selection, application or use of the products described herein can cause personal injury or property damage. If the designer or user intends to use the product for an application or use other than originally specified, he must reconfirm that the selection is suitable for the new operating conditions.



12501 Telecom Drive, Tampa, FL 33637
 Ph: (813) 978-1000 • Fax: (813) 977-3329
www.cpc-cryolab.com