

PR2352 SERIES PRESSURE RELIEVING DISCS

TABLE OF CONTENTS

LIST OF FIGURES1

INTRODUCTION.....2

CONTACT INFORMATION.....2

 GENERAL NOTES AND WARNINGS 2

INSTALLATION2

 GENERAL NOTES FOR INSTALLATION..... 2

OPERATION.....3

MAINTENANCE.....3

 GENERAL NOTES FOR MAINTENANCE 3

 SEAL REMOVAL..... 3

 SEAL INSTALLATION..... 3

LIST OF FIGURES

FIGURE 1 – PR23523

INTRODUCTION

This Installation, Operation, and Maintenance Manual is intended to be as complete and up to date as possible. It covers installation, operation, and maintenance procedures for an MEC Cryogenic product. CPC-Cryolab reserves right to update this manual and other product information concerning installation, operation, and/or maintenance, at any time and without obligation to notify product owners of such changes.

CPC-Cryolab is not responsible for injury to personnel or product damage due to improper installation, operation, and/or maintenance. All installation, operation, and maintenance procedures should only be performed by trained/certified personnel. All personnel performing these procedures should completely and carefully read and understand all supplied materials before attempting procedures. All personnel should pay strict attention to all Notes, Cautions, and Warnings that appear within procedures detailed in this manual.

CPC-Cryolab welcomes user input as to suggestions for product or manual improvement.

CONTACT INFORMATION

For information concerning warranties, or for questions pertaining to installation, operation or maintenance of CPC-CRYOLAB products, contact:

CPC-CRYOLAB
4403 Adamo Drive, Suite 305
Tampa, FL 33637

USA Phone: (813) 644-3764
www.cpc-cryolab.com

To order replacement parts, contact CPC-Cryolab at address listed above.

Note: Please include model and serial number of unit for which parts are being ordered. If ordering by phone, please have this information readily available.

GENERAL NOTES AND WARNINGS

Notes:

- If questions are not answered by this manual, or if specific installation, operation, and/or maintenance procedures are not clearly understood, contact CPC-Cryolab for clarification before proceeding.
- If unit is damaged during installation, operation, or maintenance, complete following steps:

1. Turn off and lock out all supply to unit in an approved manner, including incoming valves.
2. Contact in-house maintenance personnel or CPC-Cryolab for instructions.

NOTE: Throughout this manual, warnings will be denoted by BOXES

CAUTION!

Piping system must be adequately designed and supported to prevent extraordinary loads to pressure equipment.

It is strongly recommended that this document be reviewed before attempting any installation, operation, or maintenance procedures.

CAUTION!

Serious injury or death can occur if not handled by properly trained personnel. Please consult the manufacturer with any questions prior to conducting work on these items.

INSTALLATION

GENERAL NOTES FOR INSTALLATION

Prior to installation, the valve assembly should be unpacked and checked against the packing list and/or the approved customer drawing.

Valves must be installed in the flow-to-open orientation.

For oxygen clean and high purity valves, care must be taken to ensure the level of cleanliness is not compromised during the installation process.

OPERATION

The valve is self-contained and has no manual operation.

MAINTENANCE

WARNING!

Injury or death can occur due to failure to completely isolate equipment from all sources of pressure before beginning disassembly. Do not proceed until valve has been completely isolated from the process and vented to atmospheric

GENERAL NOTES FOR MAINTENANCE

Standard maintenance kits include only the seal (o-ring).

Apply Krytox® or any other suitable lubricant to the seal prior to reassembly. NOTE: Lubricant must be compatible with process fluid.

If easily accessible, the valve does not require removal to change the seat/disc seal.

For units with EMI protection, ensure ground cable is free of damage and connections are clean and secure.

SEAL REMOVAL

Please refer to Fig. 1 for a basic illustration of the valve.

Press on the stem end of the Poppet to open the valve sufficiently to access the O-Ring Seal.

Roll the Seal off the Body, then pull it over the Poppet to remove.

IMPORTANT!

For units with an EMI Seal, do not stretch the Seal, as this will cause it to break.

SEAL INSTALLATION

Please refer to Fig. 1 for a basic illustration of the valve.

Press on the stem end of the Poppet to open the valve sufficiently to access the O-Ring Seal.

Place the Seal over the disc end of the Poppet, then work it into the groove in the Body.

IMPORTANT!

Do not loosen or remove the Jam Nuts, as any changes to how they are reinstalled would alter the relief pressure setting..

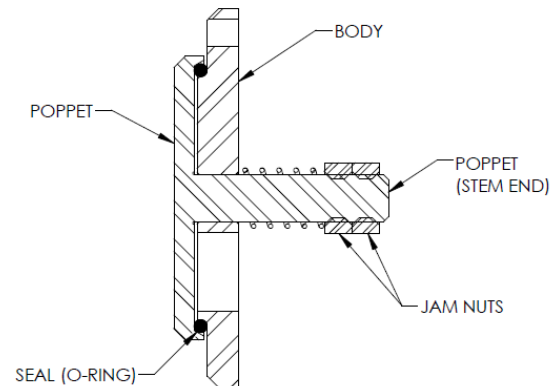

Figure 1

It is solely the responsibility of the system designer and the user to select products and materials suitable for their specific application requirements and to ensure proper installation, operation and maintenance of these products. Assistance shall be afforded with the selection of the materials based on the technical information supplied to CPC-Cryolab™; however, the system designer and user retain final responsibility. The designer should consider applicable Codes, material compatibility, product ratings and application details in the selection and application. Improper selection, application or use of the products described herein can cause personal injury or property damage. If the designer or user intends to use the product for an application or use other than originally specified, he must reconfirm that the selection is suitable for the new operating conditions.