

CV9 SERIES CRYOGENIC VALVES 1/2 Inch Size

TABLE OF CONTENTS

INTRODUCTION	2
CONTACT INFORMATION.....	2
GENERAL NOTES AND WARNINGS	2
INSTALLATION	3
GENERAL NOTES.....	3
WELDING VALVE IN PIPELINE.....	3
PNEUMATIC AND ELECTRICAL CONNECTIONS.....	3
OPERATION	3
HANDWHEEL (MANUAL)	3
DIRECT ACTING (NORMALLY OPEN, AIR-TO-CLOSE) PNEUMATIC ACTUATOR	3
REVERSE ACTING (NORMALLY CLOSED, AIR-TO-OPEN) PNEUMATIC ACTUATOR	4
START-UP	4
MAINTENANCE	4
GENERAL NOTES.....	4
STANDARD: MANUAL.....	4
<i>Disassembly</i>	4
<i>Reassembly</i>	4
STANDARD: AUTOMATIC	5
<i>Disassembly</i>	5
<i>Reassembly</i>	5

TABLE OF FIGURES

FIGURE 1 - STANDARD MANUAL VALVE.....	6
FIGURE 2 - STANDARD AUTOMATIC VALVE.....	7
FIGURE 3 - SEAT RETAINER NUT TORQUE.....	8
FIGURE 4 - VALVE MOUNTING ORIENTATIONS	9

INTRODUCTION

This Installation, Operation, and Maintenance Manual is intended to be as complete and up to date as possible. It covers installation, operation, and maintenance procedures for a CPC-Cryolab product. CPC-Cryolab reserves the right to update this manual and other product information concerning installation, operation, and/or maintenance, at any time and without obligation to notify product owners of such changes.

CPC-Cryolab is not responsible for injury to personnel or product damage due to improper installation, operation, and/or maintenance. All installation, operation, and maintenance procedures should only be performed by trained/certified personnel. All personnel performing these procedures should completely and carefully read and understand all supplied materials before proceeding. All personnel should pay strict attention to all Notes, Cautions, and Warnings that appear within procedures detailed in this manual.

CPC-Cryolab welcomes user input as to suggestions for product or manual improvement.

CONTACT INFORMATION

For information concerning warranties, or for questions pertaining to the installation, operation, or maintenance of CPC-Cryolab products, contact:

CPC-CRYOLAB
4430 E. Adamo Dr. #305
Tampa, FL 33605
USA Phone: (813) 644-3764

To order replacement parts, contact CPC-Cryolab at address listed above.

Please include model and serial number of units for which parts are being ordered. If ordering by phone, please have this information readily available.

GENERAL NOTES AND WARNINGS

Notes:

- If the manual fails to answer all questions, or if specific installation, operation, and/or - maintenance procedures are not clearly understood, contact CPC-Cryolab for clarification before proceeding.
- If the unit is damaged during installation, operation, or maintenance, complete following steps:
 1. Turn-off and lock-out all supply to the unit in an approved manner, including incoming valves.
 2. Contact in-house maintenance personnel or CPC-Cryolab for further instructions.

Throughout this manual, warnings will be denoted as shown in the example below:

CAUTION!

Piping system must be adequately designed and supported to prevent extraordinary loads to pressure equipment.

CAUTION!

Serious injury or death can occur if not handled by properly trained personnel. Please consult the manufacturer with any questions prior to conducting work.

INSTALLATION

GENERAL NOTES

Prior to installation, the valve and all associated parts should be unpacked and checked against the packing list and/or the approved customer drawing. If parts are missing or extra, contact the manufacturer.

Valves are recommended for installation in the flow-to-open orientation (under seat port to be inlet connection). Globe valves can be mounted in a horizontal pipe run with the actuator or handwheel located above the pipeline and no more than 15° to either side of the valve vertical centerline. Y-pattern valves can be mounted in a horizontal pipe run with the actuator or handwheel located above the pipeline and no more than 45° to either side of the valve's vertical centerline, and they can be mounted in a vertical pipe run with the actuator or handwheel located above the horizontal. Right angle valves can be mounted in a vertical pipe run with the actuator or handwheel located above the pipeline and no more than 45° to either side of the valve's vertical centerline. See Figure 5 (Page 10) for an illustration of valve mounting.

The valve is not to be installed or used in a pipeline that exceeds the maximum allowable working pressure listed on the valve tag.

Support the actuator as necessary to avoid inducing extraordinary loads to the bonnet extension and pipeline (especially when installing Y-pattern valves).

For oxygen clean and high purity valves, care must be taken to ensure cleanliness is maintained and not compromised during the installation process.

WELDING VALVE IN PIPELINE

Prior to welding, ensure pipeline is clean and free from things such as dirt, weld slag, machining burrs, and pipe scale. The valve ports are identified with a label as "OS" for over seat and "US" for under seat.

The valve does not require disassembly to be welded in the pipeline due to the end connection extensions. However, the valve should be in the open position prior to welding as this will minimize heat conduction to the PCTFE soft seat. Support the valve securely until it is welded into the pipeline.

Weld valve into the pipeline in accordance with all applicable local and national codes and standards.

After installation, if system flushing is necessary, first remove the inner cylinder/plug assembly (see MAINTENANCE Section) to protect the PCTFE soft seat.

PNEUMATIC AND ELECTRICAL CONNECTIONS

See the appropriate instruction manual shipped with the valve for any installed accessory including actuator, positioner, filter/regulator, solenoid, or limit switch.

When making pneumatic connections it is recommended that PTFE tape or paste is used on threaded joints unless otherwise specified by the components' instruction manual. The pneumatic supply should be clean, dry air or nitrogen.

When making electrical connections, wiring of components should be in accordance with all applicable local and national codes and standards.

OPERATION

HANDWHEEL (MANUAL)

The valve is actuated by manually turning the handwheel. The valve opens when the top face of the handwheel is turned counterclockwise. The valve closes when the top face of the handwheel is turned clockwise. The use of spanner wrenches or 'cheater bars' to close the valve restricts safe operation and could void warranty.

DIRECT ACTING (NORMALLY OPEN, AIR-TO-CLOSE) PNEUMATIC ACTUATOR

In this configuration the actuator contains springs that provide an upward force to open the valve when pneumatic supply pressure decreases. Therefore, the valve closes with increasing pneumatic supply pressure. See the actuator instruction manual and data plate for additional information.

REVERSE ACTING (NORMALLY CLOSED, AIR-TO-OPEN) PNEUMATIC ACTUATOR

In this configuration the actuator contains springs that provide a downward force to close the valve when pneumatic supply pressure decreases. Therefore, the valve opens with increasing pneumatic supply pressure. The required pre-load to achieve standard “bubble-tight” shut-off is factory set. See the actuator instruction manual and data plate for additional information.

START-UP

After initial cool down, check and re-tighten packing and body/bonnet fasteners as needed (see GENERAL NOTES in the MAINTENANCE Section).

MAINTENANCE

WARNING!

Injury or death can occur due to failure to completely isolate equipment from all sources of pressure before beginning disassembly. Do not proceed until valve has been completely isolated from the process and vented to atmospheric pressure.

GENERAL NOTES

Standard maintenance kits for valves include a soft goods kit to replace all elastomeric seals and a change out, or top works, kit to replace the entire valve except for the body. Change out kits are provided pre-assembled, ready to drop into the valve body, and can be used to convert manual valves to automatic and *vice versa*.

Apply Krytox® or any other suitable lubricant to all threads (manual stem threads, body/bonnet fasteners, and packing fasteners) and o-rings prior to reassembly. Lubricant must be compatible with process fluid!

Apply NIKAL® (nickel anti-seize compound) or any other suitable lubricant to the yoke lock nut (on automatic actuator valves) for ease of disassembly.

PCTFE soft seat fasteners are to be tightened per Figure 3 (Page 8).

Packing fasteners/nuts for all manual and automatic valves are to be tightened enough to prevent leakage under operating conditions only. Over-tightening reduces the packing life and causes excessive friction forces on the valve stem, leading to higher actuation force and premature degradation of valve performance.

STANDARD: MANUAL

Please refer to Figure 1 for a basic illustration of this valve. The number in parenthesis refers to the item number in the specified figures.

Disassembly

Change Out/Top Works Kit

After ensuring the valve is isolated from all sources of pressure and fully depressurized, remove the retaining ring (18) and spacer (19) from the top of the stem (6). Remove the internal retaining ring (14) from the inside of the knob (13) and pull the knob off the stem. Remove the second spacer (19) from the stem which exposes the internal seals. Remove the spiral retainer ring (7) from inside the bonnet (1) and pull the top works out of the valve.

Soft Goods Kit (Packing, Seat Disc, and Gaskets)

To initially access the internal components, refer to the instructions above. Remove the washers (8), Delrin® spacers (9), spring (11), and o-rings (10) from the stem (6). Take care not to scratch the stem and sealing surfaces.

To remove the seat disc (15), remove the seat disc nut (16) and slide off the seat disc (15).

NOTE: The seat disc nut may be different than shown in the figures. The seat disc nut may be profiled for linear or equal percentage flow.

Reassembly

Soft Goods Kit (O-rings, Spacers, Seat Disc)

To install a change out or top works kit only, refer to the instructions below.

Replace the seat disc (15) and seat disc nut (16) onto the valve stem (6). Torque the seat disc nut and stake it per Figure 3. Install new o-rings (10), washers (8), Delrin® spacers (9), and spring (11) on the stem per Detail A of Figure 2. Refer to the GENERAL NOTES under MAINTENANCE section for important information regarding the proper lubrication of the o-rings prior to installation.

Change Out/Top Works Kit

Carefully slide the top works through the bonnet into the valve body. Insert the spiral retaining ring (7) into the bonnet. Place one spacer (19) onto the stem (6) and thread the knob (13) on the top of the stem. Replace the internal retainer ring (14) on the inside of the knob (13). Slide the second spacer (19) onto the stem and secure the snap ring (18) on the stem groove.

Fully open and close the valve, checking for smooth operation. With the valve in mid-stroke position, pressurize the valve and check for leaks at the body/bonnet connection as well as at the sealing gland. Close the valve and depressurize the downstream side to check for seat tightness.

STANDARD: AUTOMATIC

Please refer to Figure 2 for a basic illustration of this valve. The number in parenthesis refers to the item number in the specified figures.

Disassembly

Change Out/Top Works Kit

After ensuring the valve is isolated from all sources of pressure and fully depressurized, disconnect the actuator from the valve by removing the yoke nut (5). Remove the actuator from the valve assembly. Slide off the actuator spacer (4) and loosen the actuator adapter set screw (3). Unscrew the actuator adapter (2) to expose the packing gland (Detail A). Remove the spiral retaining ring (7) and pull the top works out of the valve body by lifting up on the stem.

Soft Goods Kit (Packing, Seat Disc, and Gaskets)

To initially access the internal components, refer to the instructions above. Remove the actuator according to the instructions supplied with the actuator or contact the manufacturer.

Remove the washers (8), Delrin® spacers (9), spring (11), and o-rings (10) from the stem (6). Take care not to scratch the stem and sealing surfaces.

To remove the seat disc (15), remove the seat disc nut (17) and slide off the seat disc.

NOTE: The seat disc nut may be different than shown in the figures. The seat disc nut may be profiled for linear or equal percentage flow.

Reassembly

Soft Goods Kit (O-rings, Spacers, Seat Disc)

To install a change out or top works kit only, refer to the instructions below.

Replace the seat disc (15) and seat disc nut (17) onto the valve stem (6). Torque the seat disc nut and stake it per Figure 3. Install new o-rings (10), washers (8), Delrin® spacers (9), and spring (11) on the stem (6) per Detail A of Figure 2. Refer to the GENERAL NOTES under MAINTENANCE section for important information regarding the proper lubrication of the o-rings prior to installation.

Change Out/Top Works Kit

Carefully slide the top works through the bonnet (1) into the valve body. Insert the spiral retaining ring (7) into the bonnet. Thread the actuator adapter (2) onto the bonnet. Tighten the actuator adapter set screw (3). Slide the actuator spacer (4) onto the actuator adapter (2). Install the actuator according to the instructions supplied with the actuator or contact the manufacturer.

Fully open and close the valve, checking for smooth operation. With the valve in mid-stroke position, pressurize the valve and check for leaks at the body/bonnet connection as well as at the sealing gland. Close the valve and depressurize the downstream side to check for seat tightness.

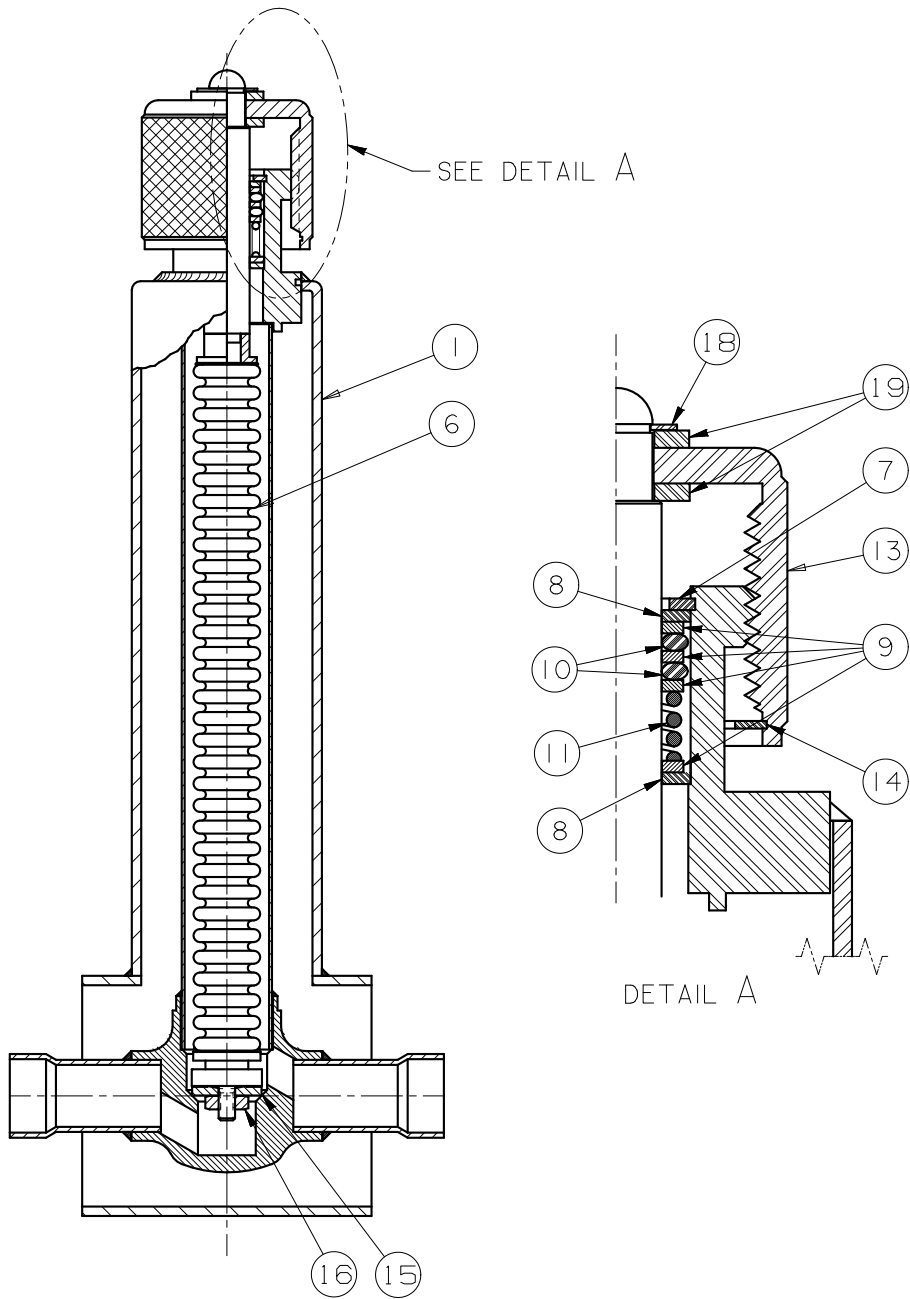

Figure 1 – CV9 Manual

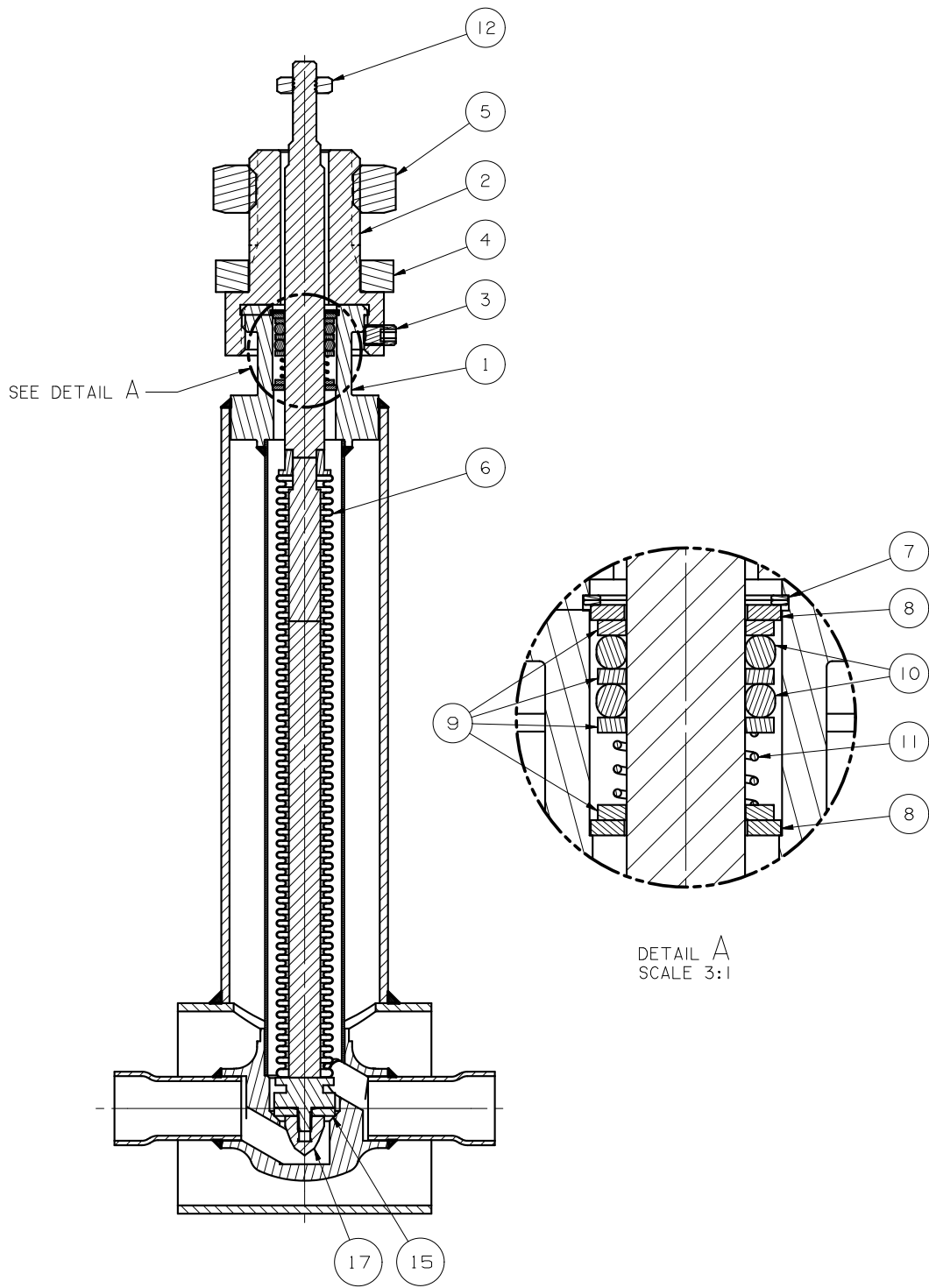
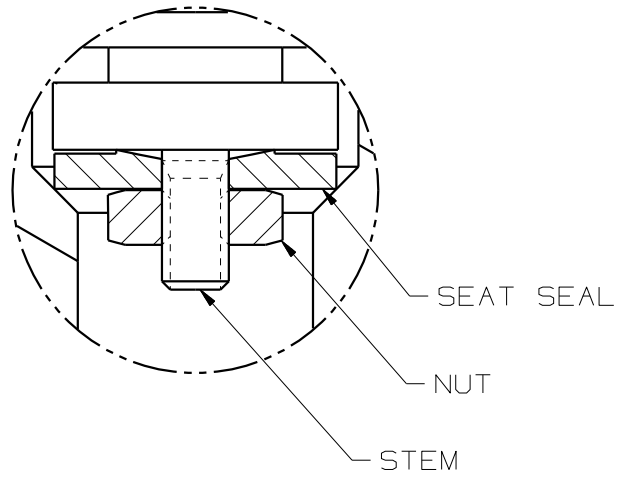
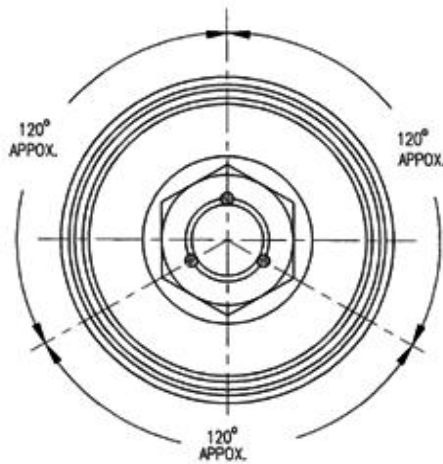

Figure 2 – CV9 Auto



Size	1/2"
Torque	8 in-lbs.
Style	Nut

NOTE: THE NUT MUST BE "STAKED" (AS SEEN BELOW) IN THREE PLACES TO ENSURE THE NUT DOES NOT WORK LOOSE DURING OPERATION. DO NOT EXCEED THE RECOMMENDED TORQUE VALUE ABOVE AS IT COULD LEAD TO MATERIAL FAILURE.



AFTER TORQUING THE SEAT RETAINER NUT, STAKE 3 (THREE) PLACES AS SHOWN ABOVE TO DEFORM THE NUT AND STUD THREADS

Figure 3 - Seat Retainer Nut Torque

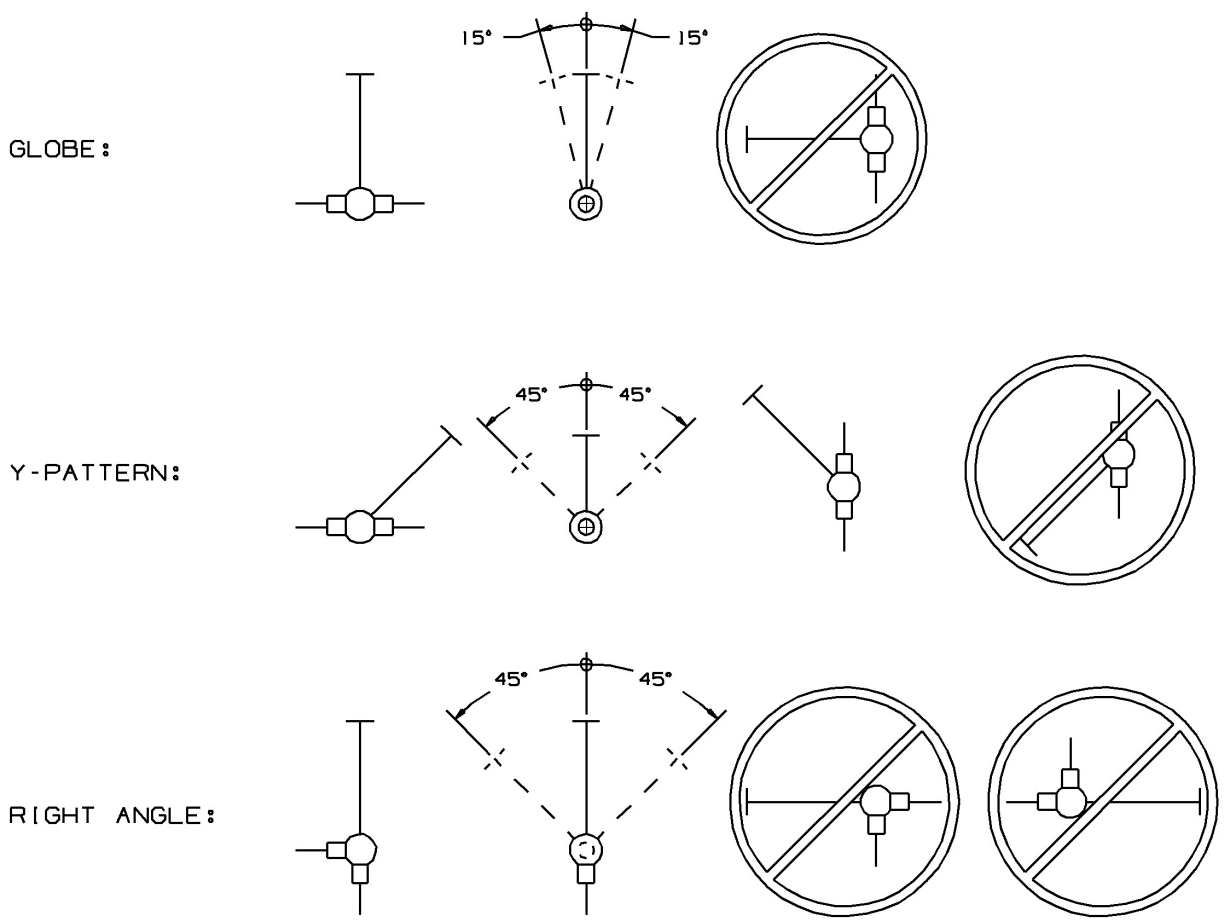

Figure 4 - Valve Mounting Orientation Examples

It is solely the responsibility of the system designer and the user to select products and materials suitable for their specific application requirements and to ensure proper installation, operation, and maintenance of these products. Assistance shall be afforded with the selection of the materials based on the technical information supplied to CPC-Cryolab™; however, the system designer and user retain final responsibility. The designer should consider applicable Codes, material compatibility, product ratings and application details in the selection and application. Improper selection, application or use of the products described herein can cause personal injury or property damage. If the designer or user intends to use the product for an application or use other than originally specified, he must reconfirm that the selection is suitable for the new operating conditions.