

BRONZE SAFETY RELIEF VALVES

TYPE RXSO

0 - 400 PSIG

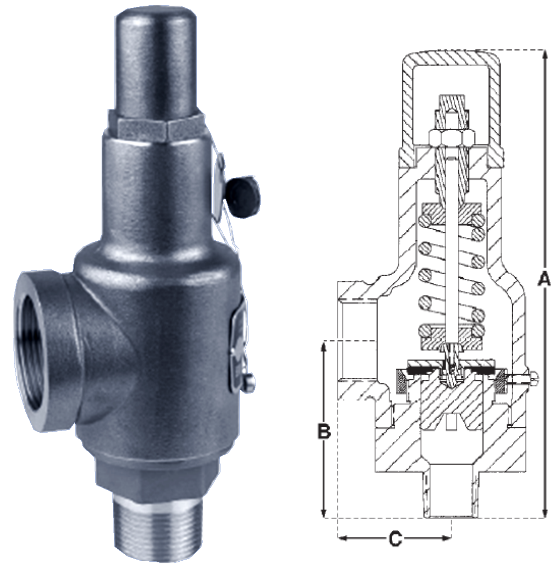

APPLICATION

- Especially recommended where noxious or expensive liquids or gases place a premium on seal quality
- Stationary Cryogenic storage tanks
- Dual Safety relief systems
- Overpressure relief of tanks, pipelines, vessels, pumps
- Air and gas compressors
- Corrosive industrial applications



APPLICABLE CODES

Designed and manufactured to meet:

- CGA S-12 and S-13
- V-4301 (Cryogenic Non-Oxygen)
- V-4401 (Oxygen)
- ASME sec VIII
- API 527
- 2014/68/EU PED (MDMT -325oF)
- CRN 0G22625.5C



FEATURES

- Special PTFE seat, making bubble-tight seals possible to over 90% of set pressures per spec API 527; not applicable to steam
- Adjustable blowdown ring
- ASME UV Certified
- Cleaned and packaged for use in O² service in compliance with the CGA specification G-4.1

Additional cleaning specifications:

- 4WPI-SW70003 • ES.660.503
- GS-38 • GS-40

Options:

- BPS threads available on most sizes
- Lever operation

Testing:

Each valve is set, tested, retested and sealed at the factory to the customer's specifications.



TECHNICAL DATA

Operating Ranges:

Temperature -423° F to +400° F
Relief Pressure to 400 PSIG

Materials of Construction:

Shell Cast Bronze,
A.S.M.E SB-62
Base Forged Brass,
Alloy C37700
Trim Copper Alloy
Spring Stainless Steel,
17-7 PH A.S.T.M.,
A-313, Type 631

Sizes:

Inlet - 1/2" to 2"
Outlet - 3/4" to 2-1/2"





DIMENSIONS & CHARACTERISTICS

Air Capacity Table

Discharge capacities in cubic feet per minute of air at 10% or 3 PSI, whichever is greater, overpressure.

Inlet Sizes Inches	1/2 3/4	1/2 3/4 1	3/4 1 1-1/4	1 1-1/4 1-1/2	1-1/4 1-1/2 2
Outlet Sizes Inches	3/4 1	1 1-1/4	1-1/4 1-1/2	1-1/2 2	2 2-1/2
Seat Diameter Inches	A 0.750	B 1.000	C 1.250	D 1.500	E 2.000
Flow Area	0.118	0.204	0.326	0.424	0.628
Set Pressure					
10	36	63	100	130	193
15	43	74	118	154	227
20	48	85	136	177	262
25	55	96	154	200	297
30	62	108	172	224	332
35	70	120	192	250	370
40	77	133	212	276	408
45	84	145	232	301	446
50	91	157	252	327	485
55	98	170	271	353	523
60	105	182	291	379	561
65	113	195	311	405	599
70	120	207	331	430	638
75	127	220	351	456	676
80	134	232	371	482	714
85	141	244	391	508	752
90	149	257	410	534	791
95	156	269	430	560	829
100	163	282	450	585	867
105	170	294	470	611	905
110	177	307	490	637	944
115	184	319	510	663	982
120	192	331	530	689	1020
125	199	344	549	715	1058
130	206	356	569	740	1097
135	213	369	589	766	1135
140	220	381	609	792	1173
145	228	393	629	818	1211
150	235	406	649	844	1249
155	242	418	668	869	1288
160	249	431	688	895	1326
165	256	443	708	921	1364
170	264	456	728	947	1402
175	271	468	748	973	1441
180	278	480	768	999	1479
185	285	493	788	1024	1517
190	292	505	807	1050	1555
195	299	518	827	1076	1594
200	307	530	847	1102	1632
205	314	543	867	1128	1670

Inlet Sizes Inches	1/2 3/4	1/2 3/4 1	3/4 1 1-1/4	1 1-1/4 1-1/2	1-1/4 1-1/2 2
Outlet Sizes Inches	3/4 1	1 1-1/4	1-1/4 1-1/2	1-1/2 2	2 2-1/2
Seat Diameter Inches	A 0.750	B 1.000	C 1.250	D 1.500	E 2.000
Flow Area	0.118	0.204	0.326	0.424	0.628
Set Pressure					
210	321	555	887	1153	1708
215	328	567	907	1179	1747
220	335	580	927	1205	1785
225	343	592	946	1231	1823
230	350	605	966	1257	1861
235	357	617	986	1283	1900
240	364	629	1006	1308	1938
245	371	642	1026	1334	1976
250	378	654	1046	1360	2014
255	386	667	1066	1386	2053
260	393	679	1085	1412	2091
265	400	692	1105	1437	2129
270	407	704	1125	1463	2167
275	414	716	1145	1489	2206
280	422	729	1165	1515	2244
285	429	741	1185	1541	2282
290	436	754	1204	1567	2320
295	443	766	1224	1592	2359
300	450	779	1244	1618	2397
305	458	791	1264	1644	2435
310	465	803	1284	1670	2473
315	472	816	1304	1696	2511
320	479	828	1324	1721	2550
325	486	841	1343	1747	2588
330	493	853	1363	1773	2626
335	501	866	1383	1799	2664
340	508	878	1403	1825	2703
345	515	890	1423	1851	2741
350	522	903	1443	1876	2779
355	529	915	1463	1902	2817
360	537	928	1482	1928	2856
365	544	940	1502	1954	2894
370	551	952	1522	1980	2932
375	558	965	1542	2005	2970
380	565	977	1562	2031	3009
385	590	989	1582	2057	3047
390	580	1002	1602	2083	3085
395	587	1015	1621	2109	3123
400	594	1027	1641	2135	3162

NOTE: Pressure Settings below 15psig (1.034 barg) are non code.

TYPE RXSO

0 - 400 PSIG



DIMENSIONS & CHARACTERISTICS

RXSO	Inlet (in)	Orifice	Outlet (in)	Max P (psi)	A Overall Height	B Overall Height	C Overall Width	Weight (lb)
71**ACD	0.5	A	0.75	400	5.78	2.44	1.34	2
71**ACE	0.5	A	1	400	6.41	2.69	1.69	3
71**ADD	0.75	A	0.75	400	5.905	2.565	1.34	2
71**ADE	0.75	A	1	400	6.535	2.815	1.69	3
71**BCE	0.5	B	1	400	7.402	2.902	1.66	3
71**BCF	0.5	B	1.25	400	7.492	2.992	1.88	3
71**BDE	0.75	B	1	400	7.402	2.902	1.66	3
71**BDF	0.75	B	1.25	400	7.492	2.992	1.88	4
71**BEE	1	B	1	400	7.402	2.902	1.66	4
71**BEF	1	B	1.25	400	7.492	2.992	1.88	5
71**CDF	0.75	C	1.25	300	8.68	3.53	2.25	4
71**CDG	0.75	C	1.5	400	9.87	3.59	2.59	4
71**CEF	1	C	1.25	300	8.65	3.5	2.25	5
71**CEG	1	C	1.5	400	9.87	3.59	2.59	6
71**CFF	1.25	C	1.25	300	8.65	3.5	2.25	6
71**CFG	1.25	C	1.5	400	9.87	3.59	2.59	6
71**DEG	1	D	1.5	350	9.84	3.56	2.59	7
71**DEH	1	D	2	400	9.69	3.69	2.75	7
71**DFG	1.25	D	1.5	350	9.84	3.56	2.59	7
71**DFH	1.25	D	2	400	9.69	3.69	2.75	9
71**DGG	1.5	D	1.5	350	9.84	3.56	2.59	9
71**DGH	1.5	D	2	400	9.69	3.69	2.75	9
71**EGH	1.5	E	2	400	9.705	3.705	2.75	10
71**EJ	1.5	E	2.5	400	9.705	4.015	2.94	10
71**EHH	2	E	2	400	9.685	3.685	2.75	10
71**EHJ	2	E	2	400	9.685	3.995	2.94	10

NOTE: Codes used for 710, 715, and 770 series

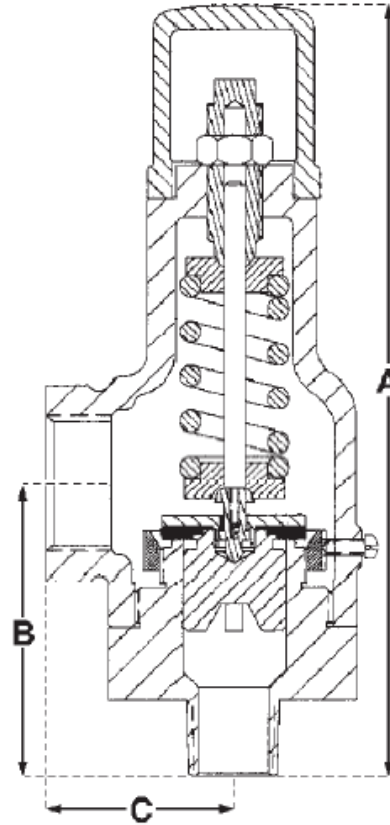

ORDERING GUIDE

SAFETY RELIEF VALVES WITH O² CLEANING

710 E A C D - A 025 - D S

MODEL NUMBER

- 710 - RXSO Bronze ASME coded - gas
- 715 - RXSO Bronze PED coded - gas
- 760 - RXSO-S Stainless Steel RXSO - gas
- 765 - RXSO-S Stainless Steel PED coded - gas
- 770 - RSL Bronze Non ASME coded - liquid
- 775 - RSL SS Non ASME coded - liquid

CAP SIZE

- N - Plain Cap
- E - Open Lever

ORIFICE

- A - 0.750
- B - 1.000
- C - 1.250
- D - 1.500
- E - 2.000

INLET SIZE

- C - 1/2"
- D - 3/4"
- E - 1"
- F - 1-1/4"
- G - 1-1/2"
- H - 2"

CUSTOMER TAGS (OPTIONAL)

- S - Stainless Steel Tag
- T - Brass Tag

DOCUMENTATION

- D - Standard (ASME)
- K - KGS Certified

SET PRESSURE

Set pressure

VALVE SERVICE (FOR SET VALVES)

- A - Air/Gas Sec. VIII
- N - Liquid Non Code (770 and 775 only)

OUTLET SIZE

- D - 3/4"
- E - 1"
- F - 1-1/4"
- G - 1-1/2"
- H - 2"
- J - 2-1/2"

EX: 1/2" x 3/4" RXSO Bronze body ASME coded, with open lever, air/gas Sec VIII set @ 25 psi with standard documentation and stainless steel tag = 710EACD-A025-DS